

GB

TOP-MOUNT REFRIGERATOR

Table of Contents 1
Kitchen Layout Installation 2
Installation, Use and Care Guide 4

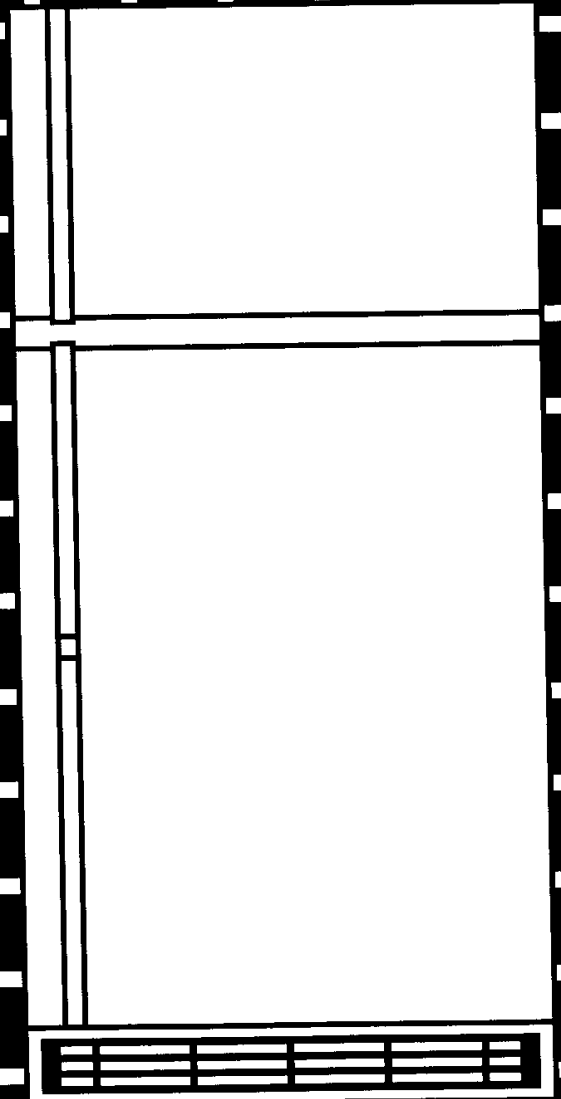
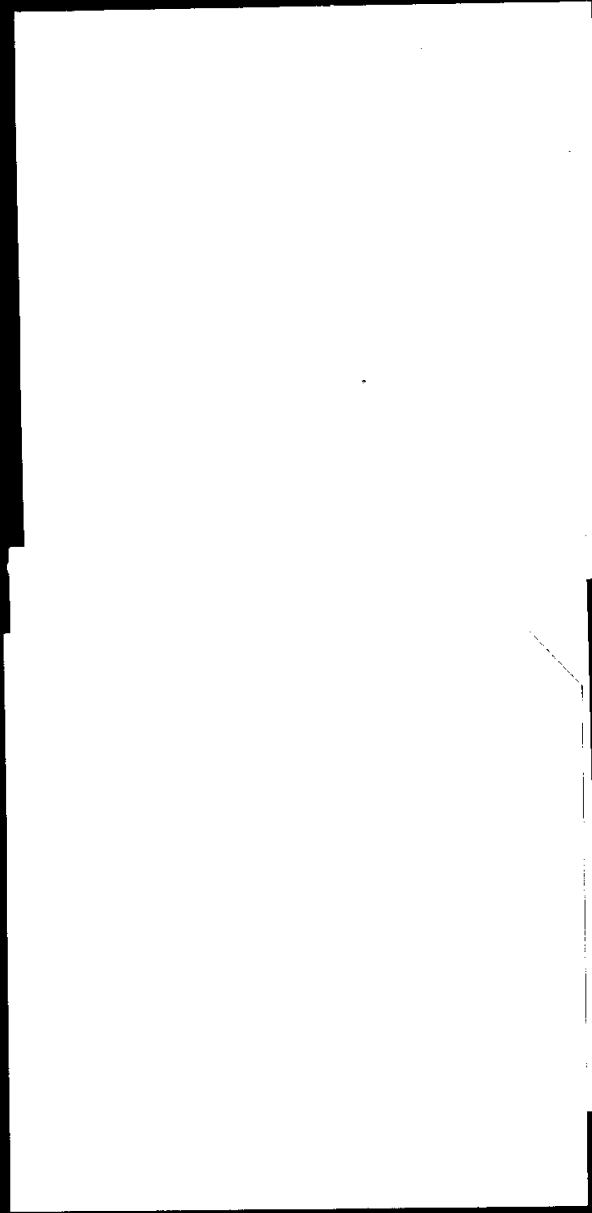
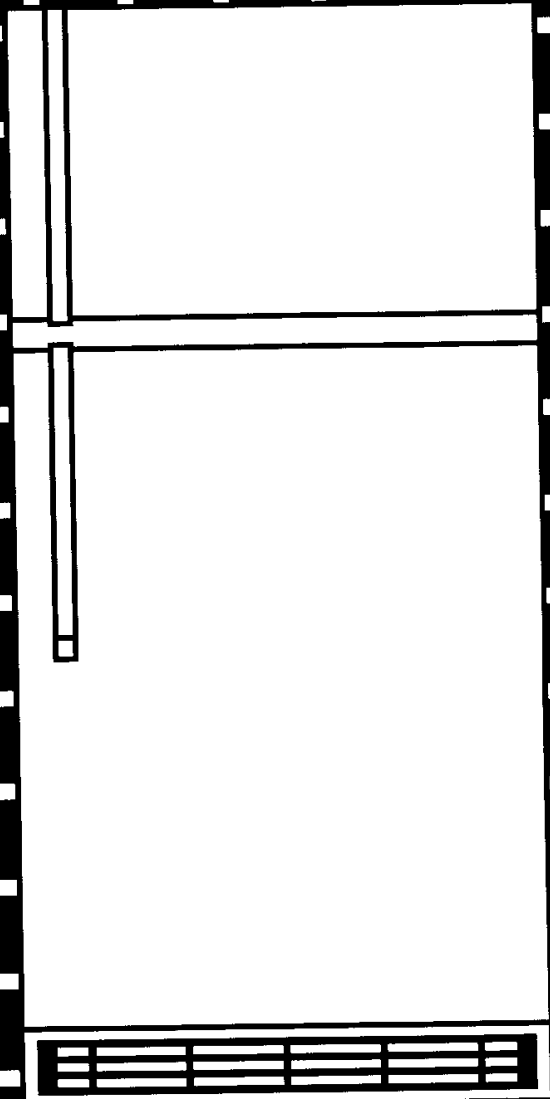
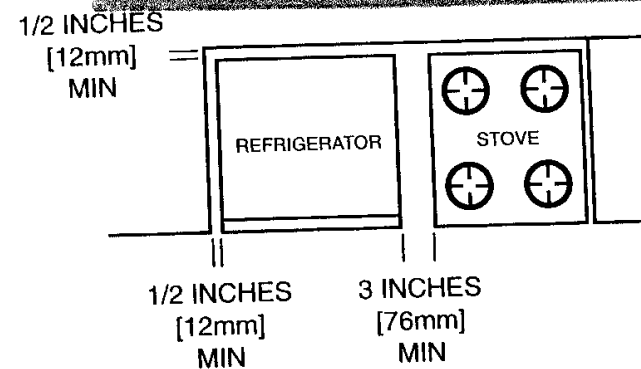
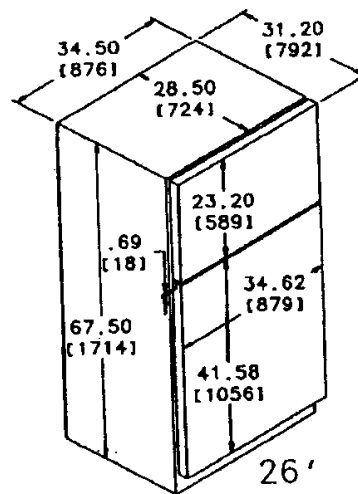
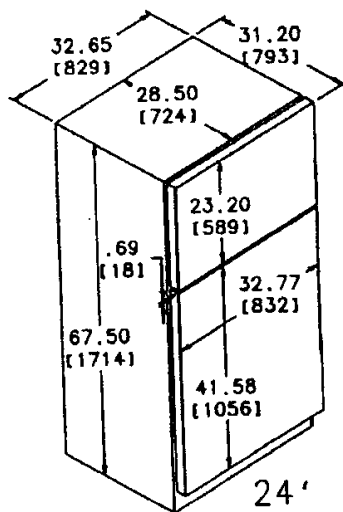
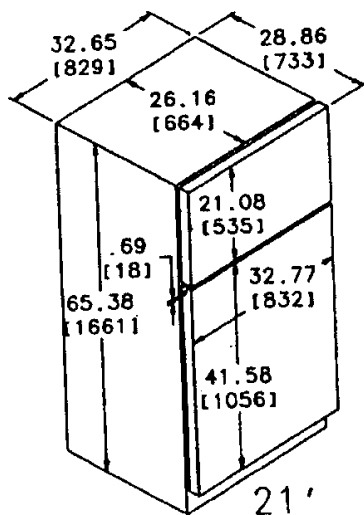
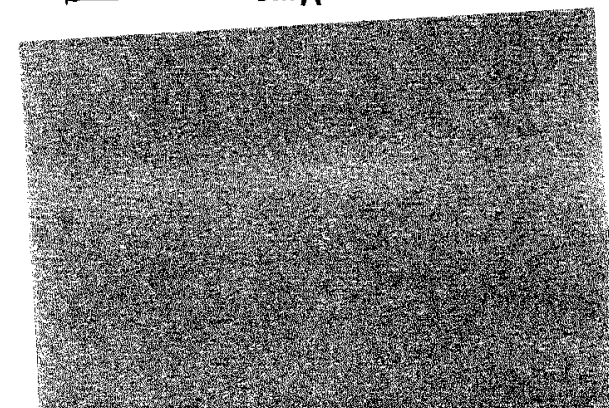
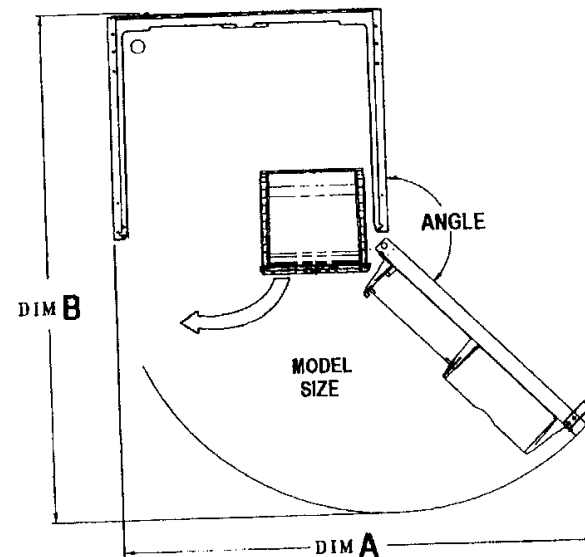
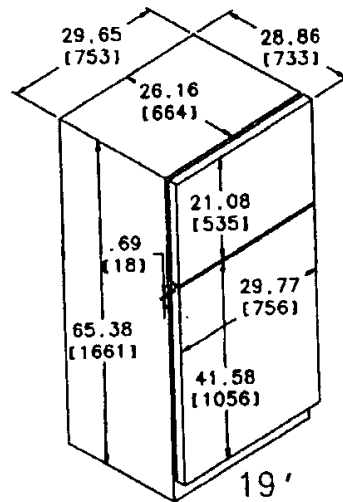
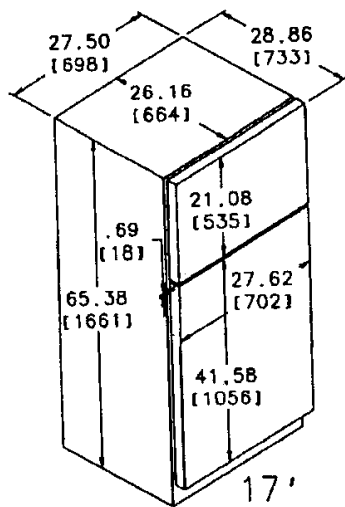
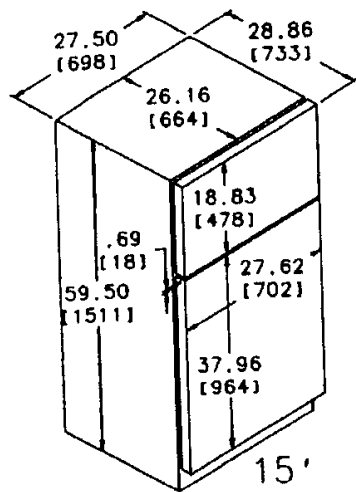

Table of Contents **GB**

Kitchen Layout Installation	2-3
General Features	4
Your New Refrigerator	5-6
Disposal of the old unit	
Disposal of the new unit packaging	
Safety precautions and warning observations	
Intended application	
Installation	
Location	
Leveling	
Warm cabinet surfaces	
Operating Instructions	6
No defrosting	
Setting controls	
Fresh food & freezer compartment controls (certain models)	
Slide controls (certain models)	
Special Storage Areas	6
Meat keeper or utility pan	
Crispers	
Fresh Food Compartment Features	7
Shelves	
Spill catcher sleeves	
Beverage rack	
Freezer Compartment Features	7
Freezer shelves	
Ice cube trays	
Optional automatic ice maker	
Automatic ice maker	
Door Features	7-8
Shelves	
Egg storage	
Dairy compartment	
Bottle retainer	
Package dividers	
Tilt out basket	
Magnetic door seals	
Reversing Doors	8-9
Energy saving tips	
Care and Cleaning	9
Replacing a light bulb	
Cleaning	
Going on vacation	
How to Obtain Replacement Parts and Services	10



GB	TOTAL GROSS ISO VOLUME	CABINET HEIGHT WITH WHEELS		ANGLE @ 135° DIM A SEE NOTE #4		ANGLE @ 107° DIM A SEE NOTE #3		DIM B SEE NOTE #5	MODEL SIZE
		INCHES	[mm]	INCHES	[mm]	INCHES	[mm]		
	420 LITERS	60.12	[1527]	53.05	[1348]	47.30	[1201]	55.34 [1406]	15'
	470 LITERS	66.00	[1676]	53.05	[1348]	47.30	[1201]	55.34 [1406]	17'
	520 LITERS	66.00	[1676]	56.72	[1441]	50.97	[1295]	57.49 [1460]	19'
	580 LITERS	66.00	[1676]	61.84	[1571]	56.09	[1425]	60.48 [1536]	21'
	680 LITERS	68.12	[1730]	61.84	[1571]	56.09	[1425]	62.82 [1596]	24'
	720 LITERS	68.12	[1730]	65.00	[1651]	59.25	[1505]	64.67 [1643]	26'

GB

NOTES:

1. TOP OF FREEZER DOOR PANEL IS .200 [5mm] ABOVE TOP OF CABINET SHELL.
2. CABINET HEIGHT IS .625 [16mm] HIGHER THAN SHELL HEIGHT DUE TO WHEELS.
3. 107° DOOR SWING IS DOOR OPENED TO DOOR STOP.
4. 135° DOOR SWING IS MINIMUM TO REMOVE CRISPER PAN NEAREST TO DOOR.
5. DIM "B" IS MAXIMUM DIMENSION FROM CABINET BACK TO DOOR TIP (OF OPEN DOOR).

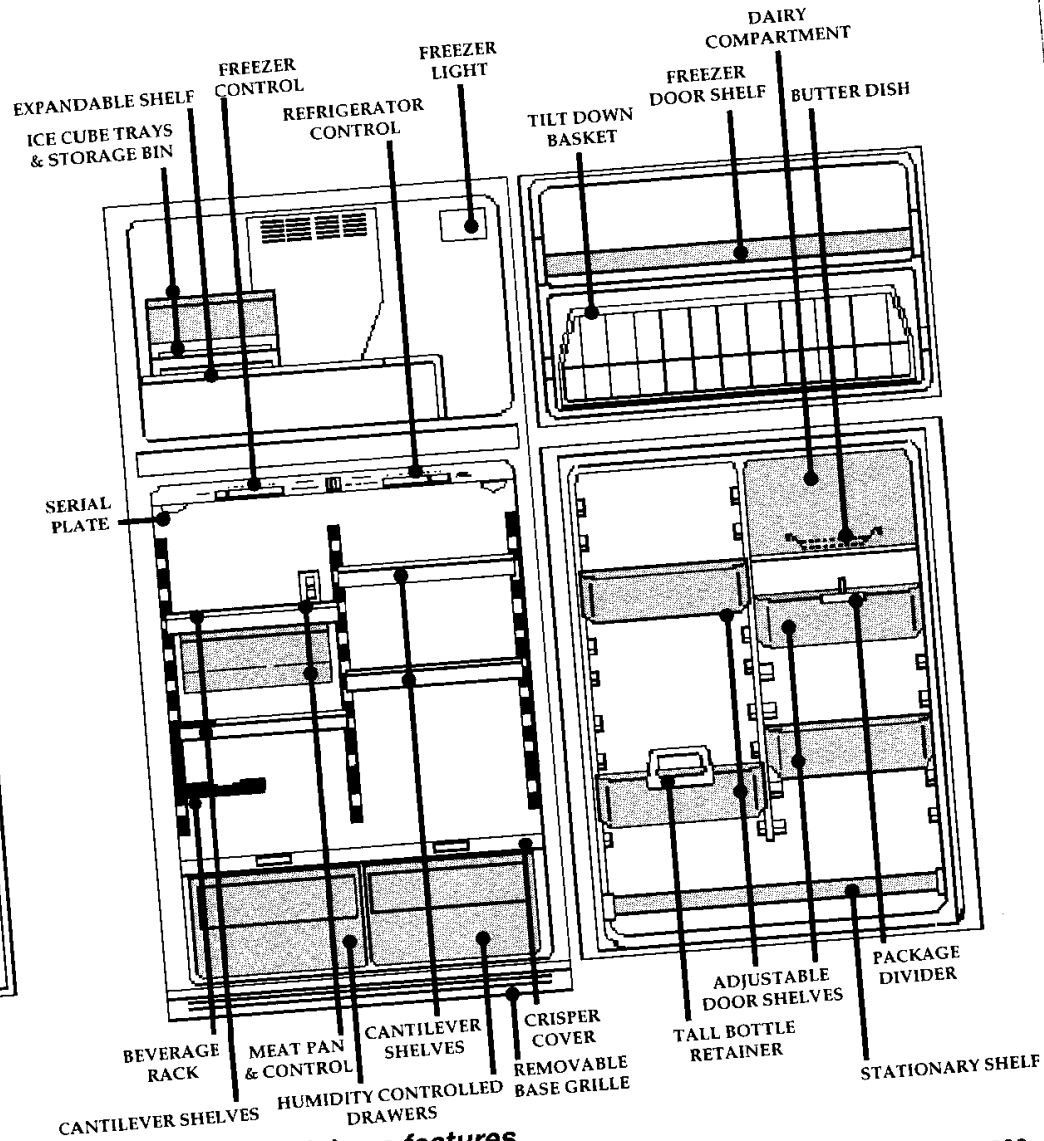
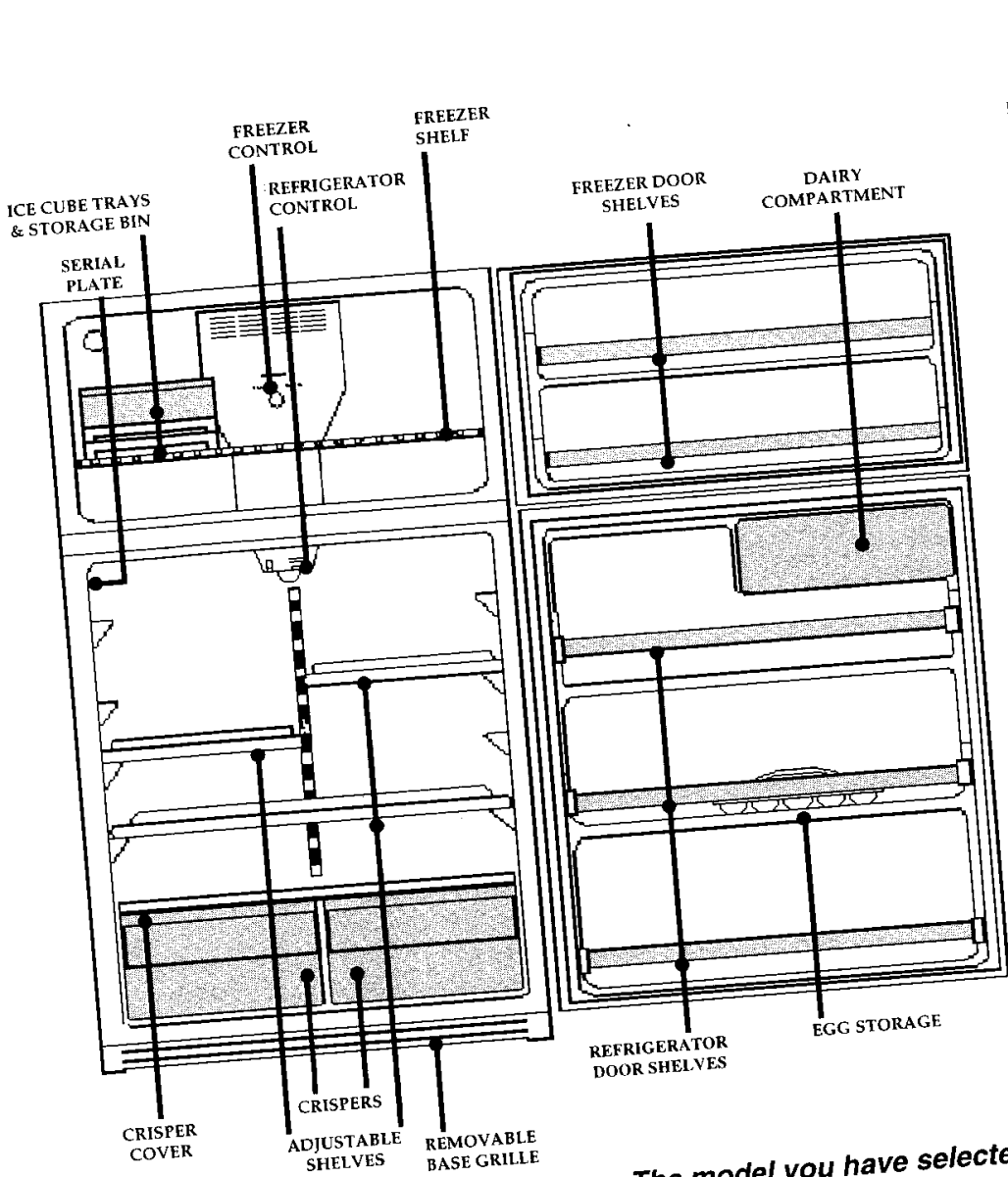

The model you have selected may not have all of these features.

Your new refrigerator is designed to provide excellent performance, ease of cleaning and reliable operation. Please read this Use and Care Guide thoroughly. It will help you operate and maintain your refrigerator properly.

Record the ① model number, ② serial number and ③ revision number of this refrigerator in the space provided. The information is found inside the refrigerator compartment on the upper left side. An example of the serial plate is shown to the left. Retain this Use and Care Guide for future reference. Give it to the New Owner if you ever sell your refrigerator.

① Model No. _____ ② Serial No. _____ ③ Rev. No. _____

GENERAL FEATURES

SERIAL PLATE

BRAND NAME
CITY STATE
USA ZIP CODE
EIGENSICHER-DIN8975
FOR ICEMAKER OPTION
USE KIT UK1000

MODEL NO. ①
SERIAL NO. ②
REV. NO. ③
MAX. AMPS. ④
ELEC. RATING ⑥

⑤ R134a 0. ___ KG
⑦ PA MAX 30 BAR

MADE IN U.S.A.

Appliance
Registration

GB

Proper Disposal of Your Old Scrap Refrigerator

(Not being Resold)

IMPORTANT: Child entrapment and suffocation are not problems of the past. Junked or abandoned refrigerators are still dangerous ... even if they will sit for "just a few days." If you are getting rid of your old refrigerator, please follow the instructions below to help prevent accidents.

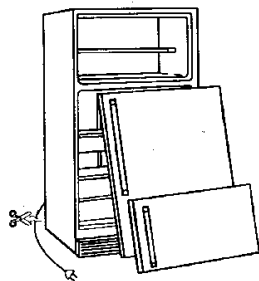

BEFORE YOU THROW AWAY YOUR OLD REFRIGERATOR OR FREEZER:

- Take off the doors.
- Leave the shelves in place so that children may not easily climb inside.
- Cut off Power Cord.

Disposal of the old unit

Safety precautions

To prevent the possibility of hazard, render your old unit safe and inoperative as shown above.

Indications for the protection of the environment

The older versions of refrigerating and deep freezer units contain chlorofluorocarbons (CFC) both in the cooling circuit and in the insulation. Chlorofluorocarbons (CFC), if set free, can damage the ozone strata in the atmosphere. Entrust the disposal of the old unit to the competence of your local waste disposal service. Please ensure that the pipework of your cooling unit does not get damaged prior to being collected by the relevant service.

Disposal of the new unit packaging

All of the packaging material used in your new unit is of the nonhazardous, disposable type.

The carton may be torn into small pieces and included in the normal household waste paper collection.

The band is made of steel and the padding is made of CFC-free polystyrene (PS). These useful materials can be further treated and recycled if you take them to the appropriate materials collection center (Recycling).

Consult your local council for the addresses of the nearest recycling center and units scrap yard nearest to your home.

Safety precautions and warning observations

Before you start-up the unit, you should read most attentively the information contained in the manual of operation and installation instructions. These provide very important specifications which should be adhered to when installing, operating or servicing the unit. Keep both instruction manuals in a safe place and remember to hand them over to a possible subsequent owner.

To prevent the possibility of hazard due to electrical shock, never plug refrigerator into a receptacle that has not been grounded adequately and in accordance with local and national electrical codes.

The manufacturer will not be held responsible for any damages resulting from nonobservance of the following:

- Do not start-up a unit showing any signs of damage. If in doubt, consult your dealer.
- Connection and installation of the unit are to be carried out in strict compliance with the specifications contained in the manuals of operation and installation instructions. The connection conditions must coincide with the data featured on the identification plates.
- **It is imperative that repairs and maintenance of the unit be categorically performed by a qualified technician.** Improper repairs carried out by persons lacking the necessary technical competence are a potential source of danger and may have critical consequences for the user of the unit.
- High-proof alcohol must be stored in tightly closed bottles or containers and these always kept in an upright position. Under no circumstances should explosive substances be stored inside the unit. **Danger of explosion!**
- Do not operate refrigerator in the presence of explosive fumes.
- Do not take ice cubes straight from the deep freezer into your mouth. (Allow to stand for a few minutes to avoid freezer burn.)
- Ensure that the circuit of the refrigerating agent is not damaged, i.e. do not pierce the refrigerant conduits with sharp items, twist or bend the pipework, scrape off coated surfaces etc. Observe that if refrigerant agent spurts out and gets into your eyes it may lead to serious eye injuries.
- Do not cover or block the air relief slots or front base grille of your cooling unit. Keep clean (see Care & Cleaning).

Intended application

- The unit was designed specifically for household use. It is suitable for the refrigeration of food, for the storage of frozen food products and for making ice cubes.
- If using for commercial purposes, please observe the statutory regulations applicable for the corresponding trade sector.
- The unit is interference-screened in accordance with EU regulation 87/398 EEC.
- It adheres to current German regulations of the prevention of accidents caused by refrigerating equipment (VBG 20).
- The cooling circuit has been subjected to the necessary leak tests.
- The unit observes all current safety regulations applicable to electrical appliances.

Follow these safety guidelines:

- Unplug refrigerator before cleaning condenser or replacing a light bulb.
- In case of power failure, minimize door openings. Frozen foods that have thawed completely should not be refrozen.
- Children should not climb, hang or stand on doors or shelves.

WARNING: Electrical Connection. See Serial Plate.

See Serial Plate for Electrical Voltage and Frequency to ensure compatibility with your home's power supply. Use with a separate, dedicated grounded (Earthed) circuit protected with a slow blow 10 A fuse or circuit breaker.

If the plug cap does not match the local receptacle, a molded cap and cord can be purchased from your local authorized dealer or service facility. **The cord should be installed by a qualified technician.** The cap and cord type are shown below. The 70 ___ base number is the compressor connection type, the dash number (-1 to -9), the plug type.

A power cord example: 70702-1 is a "Schuko Plug" molded onto a power cord for mounting on a later production compressor with 3 male terminals. See serial plate for Rev. number.

Base Number: 70652 Early Production Rev. 10	1 Female 1 Ring 1 Female	Base Number: 70702 Later Production Rev. 11	3 Female

DASH NUMBER -1 TO -9 PLUGS

-1 SCHUKO	-2 BS1363 -13A FUSE
-3 SEV1011	-4 NEMA 5-15
-5 AS 3112	-6 BS546
-7 SI32	-8 Afsint 107-2-01
-9 CEI 23-16/VII	

Fresh Food Compartment Features

Shelves

Before adjusting or removing shelves, be sure to remove all food items.

Full Width Shelves: Some models have full width shelves that rest on liner support rails. To remove, lift the front end and pull the shelf straight out. Reinsert the shelf into matching support rails (see Fig. 3).

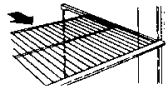

Fig. 3

Adjustable Cantilever Shelves: Glass or wire cantilever shelves may be available with your refrigerator. To remove a shelf, lift the rear straight up a fraction of an inch and pull straight out. To lock the shelf into another position, tilt the shelf with the front up. Insert hooks into desired frame openings and let the shelf settle into place. On certain models the outside surface of the shelf rests on the liner support rails (see Fig. 4).

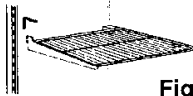
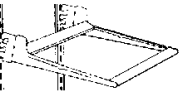

Fig. 4

Spill Catcher Shelves

The Spill Catcher Shelves in the fresh food compartment have a spill retainer edge which allows for easy clean up when spills occur. Some are also equipped with a convenient Slide Out feature.



Beverage Rack

Your model may have a multi-use Beverage Rack. Position the beverage rack to rest on the left hand side of a refrigerator shelf. This feature provides storage for an egg carton, bottle or cans on the rack.

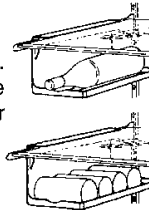

Freezer Compartment Features

Freezer Shelves

Some models are equipped with an adjustable freezer shelf. This shelf can be removed by lifting the left end up about 7.5 cm and pulling the right end bars out of the cups in the side wall. Reposition the removable supports on the left hand side of the freezer. Reverse this procedure to replace the shelf (See Fig. 5).

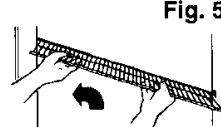

Fig. 5

Some models have an expandable-width freezer shelf which adjusts sideways to open up a full-height space for tall and narrow packages. The right side of the shelf is supported by a wide leg that slides sideways in channels on the underside of the shelf. The shelf can also adjust to two heights. This requires removing the shelf from the freezer, sliding the leg out of the channels, re-inserting it in the alternate height position and returning the shelf to the freezer,

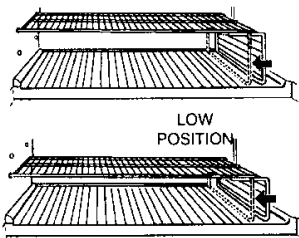

Fig. 6

inserting the left end into liner cups. (Usually, the right support section will be expanded fully to the right wall surface, unless vertical storage of tall and narrow packages is desired.) (See Fig. 6.)

Some models are equipped with an expandable-width freezer shelf and a partial shelf positioned on the left side. It is supported on the left by cups in the freezer wall and on the right by resting directly on the expandable shelf (See Fig. 7).

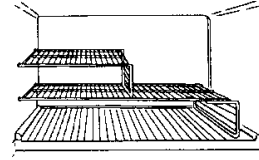

Fig. 7

Ice Cube Trays

To release ice cubes, hold the tray upside-down over a container and twist both ends.

Optional Automatic Ice Maker

Some models are designed so an Automatic Ice Maker can be easily installed whenever you want. If your model is equipped for a dealer installed ice maker option it will be listed on the serial plate in the fresh food compartment. Have your dealer order and install the kit listed (see pg. 10). The kit contains installation instructions, water connection instructions and other information concerning the ice maker operation.

Automatic Ice Maker

MODELS WITH AUTOMATIC ICE MAKER

The water inlet tubing assembly required to complete the water connection to the water valve is located in the crisper drawer in a bag. Connect the ice maker to the water supply as instructed in the separate instructions furnished with the refrigerator.

The automatic ice maker is designed to furnish a continual supply of ice cubes. With this useful feature, you no longer have the inconvenience of filling ice cube trays, or the frustration of running out of ice.

We suggest you start with your refrigerator and freezer controls at their mid settings. In most cases, this is satisfactory. If the door to the freezer is opened frequently or temperatures in the kitchen are abnormally low, a colder setting may be necessary.

After your model has been installed and the water supply connected to the ice maker, it may be 8 to 12 hours before the ice maker furnishes any usable ice cubes. The first one or two harvests will probably contain undersized and irregular cubes because of air in the supply line.

The initial harvest may also contain impurities from the new water supply piping. Therefore, all cubes from the first two or three harvests should be discarded. Once this initial period is past, your ice maker will perform steadily and dependably.

Ice cubes that have been in the ice storage bin for a considerable length of time may pick up an off-flavor taste, stick together and gradually become smaller. We suggest that these cubes be thrown away. We also suggest placing an open box of baking soda in the refrigerator for food odor absorption.

Certain sounds may accompany the various cycles of the ice maker. The motor may have a slight hum---the cubes will rattle as they fall into an empty storage pan---the water valve may click or "buzz" occasionally. All of these sounds are normal and should be ignored.

The ice maker has a wire sensor arm that is connected to a shut-off switch, see Fig. 10. This arm stops the mechanism when the ice cube storage pan is full, and restarts it as ice is used. You can use the stop arm to stop all production of ice at any time by raising the sensor arm into the OFF position.

The ice maker should be turned off (arm up) when:

1. Ice storage bin is removed for extended period of time.
2. Refrigerator will not be used for a considerable time, such as vacations. Also, turn off the water supply to the ice maker in this instance, if practical.
3. The water supply is shut off.

HOW THE ICE MAKER WORKS:

Water fills the empty cube mold (Fig. 8) when the freezer compartment has cooled to freezing temperature. Cold air is forced directly over the mold. When frozen, the cubes are rotated up and out of the mold (Fig. 9). The sweeper arm ejects them into the storage bin below. The sensor arm senses when the bin is full and signals the ice maker to stop ejecting more cubes (Fig. 10). Meanwhile, the mold has been refilled and cubes frozen so the new supply is ready when needed. As soon as ice is removed from the bin, the sensor arm signals that more is needed. The ice maker resumes operation by ejecting ready-and-waiting frozen cubes.

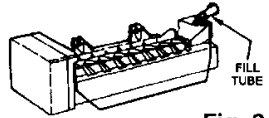

Fig. 8

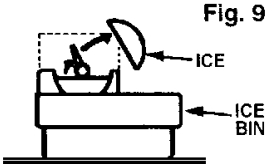

Fig. 9

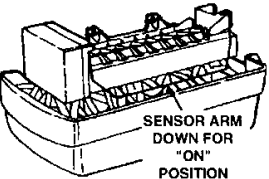

Fig. 10

FOR YOUR SAFETY

Do not place fingers or hands on the automatic ice making mechanism while the refrigerator is plugged in. This will help protect you from possible injury. It will also prevent interference with moving parts of the ejector mechanism and the heating element that releases the cubes.

Under certain rare circumstances, ice cubes may be discolored, usually appearing with a green-bluish hue. The cause of this unusual discoloration can be a combination of factors such as certain characteristics of local waters, household plumbing and the accumulation of copper salts in an inactive water supply line which feeds the ice maker.

Continued consumption of such discolored ice cubes may be injurious to health. If such discoloration is observed, discard the ice cubes and contact your dealer to purchase and install a water line filter.

Door Features

There are several different features available for the refrigerator doors, depending upon the model you have selected.

Shelves

Some models have removable shelves that are adjustable. Lift the shelf front up until it clears the retainers on the door liner and pull straight out. Reverse this procedure when replacing a shelf (See Fig. 11).

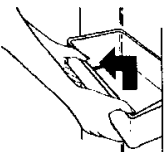

Fig. 11

Egg Storage

The egg tray holds a "dozen-plus" eggs and fits securely on a door shelf. This tray can be removed and carried to your working area.

Dairy Compartment

Special, extra deep dairy compartment stores butter and cheeses.

Bottle Retainer

Some models have a bottle retainer located on the lower refrigerator door shelf, see page 2. It prevents tall bottles from falling out when the refrigerator door is opened or closed. To attach the retainer in models with door bins, have the smooth side of the retainer facing forward, align the retainer with the front lip of the bin and snap into position. The bottle retainer can be adjusted to any position on the bin by sliding it sideways.

Package Dividers

Some models have a package divider located on the refrigerator door shelves, see page 2. It provides upright storage for packages or bottles. The divider can be adjusted to any position on the shelf by sliding it sideways.

Tilt Out Basket

Some models have a tilt out basket on the lower shelf of the freezer door. Tilting the basket forward provides easy access to packages. A slight push upward will tilt the basket back to its proper stored position (See Fig. 12).

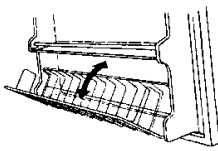

Fig. 12

Magnetic Door Seals

Door seals are magnetized to insure an air-tight seal.

Reversing Doors



Your refrigerator has been designed with the flexibility of changing door swing if desired. The following instructions describe changing door swing from "right to left". For "left to right" merely transpose all references to "right and left".

Tools Required

T-15 Torx driver
Putty Knife

5/16" Socket and ratchet
or 5/16" End Wrench
(5/16" = 8mm)

To Change the Doors

1. Turn the fresh food control to OFF or O, unplug the refrigerator and remove all food from the interior.
2. Remove the handles from the doors and set aside. (See Fig. 13 and Fig. 14.) On some models the bottom mounting screw on the lower door handle is covered with a cap. Carefully pry it out to expose the screw. The cap should be saved for reassembly after the handle is remounted. On the side (front) of the lower door where you are going to install the handle, remove the small round screw hole plug going to install the handle, remove the small round screw hole plug with a putty knife and press it into the corresponding hole on the opposite side of the door. If your model has side mount handles, the screw heads are covered with plastic caps that should be carefully removed and saved for reassembly after the handles are remounted. On the side of the door that you are going to install the handle, remove the small round screw hole plugs with a putty knife and press them into the corresponding holes on the opposite side

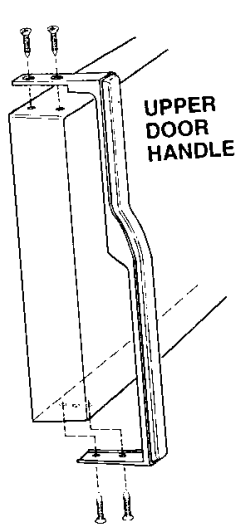

Fig. 13

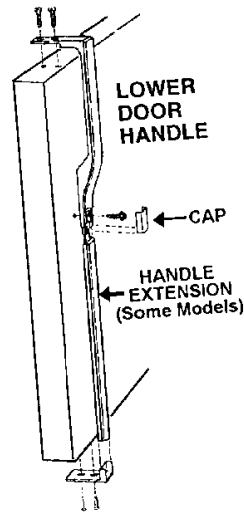

Fig. 14

3. Using a 5/16" socket and ratchet, remove the screws from the upper hinge. Carefully lift the door (including the upper hinge) off the center hinge and place it on a padded surface to prevent scratching. Retain the hinge shim for later reassembly.
4. With a putty knife, remove the screw hole plugs opposite the top hinge side and install them in the original top hinge mounting screw holes.
5. With a 5/16" socket and ratchet, remove the screw visible from the front on the center hinge. Slide the center hinge and the top of the door towards the opposite center hinge side until it clears the shoulder screw. Now, carefully lift the lower door off the lower hinge and place it on a padded surface. If the hinge pin (and washers) pulls out of the lower hinge when the door is removed, pull it out of the door bottom and press it back into the hinge in the same location that it came out of.
6. With a putty knife, remove the screw hole plugs on the opposite side of the original center hinge location and set them aside. With a 5/16" socket and ratchet, remove the shoulder screw on the original center hinge side and put it in the hole on the opposite side. Now, take the screw hole plugs, previously set aside, and place them in the holes where the center hinge was originally located.
7. With a putty knife, remove the screw hole plugs on the opposite side of the bottom hinge and set them aside (Some models do not have these hole plugs). Remove the base grille (see page 9, Fig. 17). With a 5/16" socket and ratchet, remove the three screws from the bottom hinge and shim. Remount the bottom hinge and shim with the same screws on the opposite side. The bottom hinge should be slid as far as it can towards the side of the cabinet.
8. Remove the hinge pin and washer from the bottom hinge and place it into the opposite hole of the hinge. Note: The hinge pin should be in the hole closest to the outside wall of the refrigerator and the hinge pin can only go in one direction.

9. With a putty knife, remove the hinge cup plug from the top of the freezer door and refrigerator door and set them aside. Take the center hinge, screw and washers out of the top of the refrigerator door and put it on the opposite side. Note: One door washer goes between the center hinge and the top of the lower door and two door washers go between the center hinge and freezer door. Take the top hinge out of the top of the freezer door and put it on the opposite side. Now, take the hinge cup plugs and place them in the hinge cup opposite the center hinge and top hinge.
10. Some models have door stops mounted to the bottom of the refrigerator door and freezer door. With a T-15 Torx driver, remove the screws holding the door stops and remount the door stops to the opposite side of the door. Avoid over tightening this screw. Tighten them until they are just snug then turn them in another half turn.
11. Take the lower door and center hinge and place it onto the bottom hinge pin. Make sure the bottom hinge pin enters the bushing at the bottom of the door. Position the door in the opening and slide the center hinge over the shoulder screw. Now tighten the screw, closest to the new handle location, on the center hinge. Avoid over tightening this screw. Reverse the ends of the base grille and reinstall to the cabinet base (see Fig. 17).
12. Set the upper door on the center hinge, making sure the hinge pin enters the bushing on the bottom of the door. When you close this door, the magnetic seal will hold it in place.
13. Position the hinge shim to the new location and install the top hinge with the three mounting screws. Before tightening these screws, make sure the top of the door is level with the cabinet top and the space between the door is equidistant across the entire front. Avoid over tightening these screws. Tighten them until they are just snug then turn in another half turn.
14. Examine the entire door seal around each door, making sure no gaps are visible between the seal and cabinet. If a gap shows, try stretching the seal away from the door. The magnet will contact the cabinet surface.
15. Install the handles on the opposite side of door as shown in figure 15. If your model has side mount handles, install the handles as shown in figure 16.
16. Replace all food and return the fresh food control to its usual operating position.

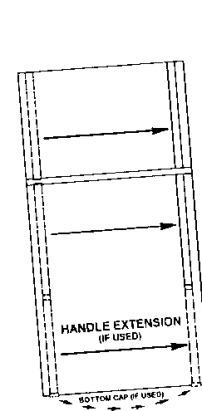

Fig. 15

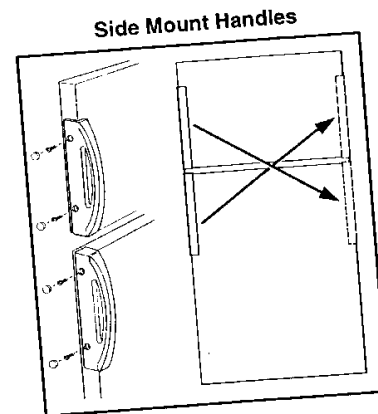

Fig. 16

Energy Saving Tips

- Be sure refrigerator is level and ventilation around front grille is not blocked.
- Leave 1.25 cm or more clearance around the top, back and sides for ventilation.
- Check door seals occasionally for leakage. Check at various places, top, bottom and sides.
- Check the temperature, avoid unnecessarily cold settings.
- Keep freezer full to near capacity. Less cold air is lost during door openings.
- Cool hot dishes before putting them into the refrigerator or freezer.
- Cover liquids.

Care & Cleaning



Replacing A Light Bulb

DISCONNECT THE POWER CORD BEFORE REPLACING LIGHT BULBS.

Always use a specified, standard base, appliance type bulb when replacing a light bulb.

Cleaning

DISCONNECT POWER CORD BEFORE CLEANING. Your refrigerator can be moved out for cleaning. If your model has an automatic ice maker, we recommend that you turn the water supply off before moving the cabinet.

After cleaning behind your model, push it back and turn the levelers clockwise to lock cabinet in place.

Inside

Clean both compartments and inner door panels with mild soap and water. DO NOT use an abrasive powder, solvent, polish cleaner or undiluted detergent. Use baking soda and warm water only on interior compartments and interior door liners. Rinse with clear water. Do not wash interior parts in your dishwasher. Be sure to wring out excess water from the sponge or cloth when cleaning in the area of controls, lights or electrical parts.

Glass shelves can be removed and completely immersed in warm water. ALLOW GLASS TO WARM TO ROOM TEMPERATURE BEFORE IMMERSING.

Outside

Keep the finish clean. Wipe with a clean, soft cloth lightly dampened with a mild liquid dishwashing detergent. Dry and polish with a clean, soft cloth. Do not wipe the refrigerator with a soiled dishwashing cloth or wet towel. These may leave residue that can scratch and weaken the paint. Do not use scouring pads, powdered cleansers, bleach or cleaners containing bleach because these products can scratch and erode the paint finish.

Your door seals are vinyl. They may be cleaned with a baking soda solution, soap and water, or with a mild scouring powder.

Removing Base Grille (Some Models)

Grasp the base grille at both ends and pull straight out. To replace the base grille, align the spring clips with the round openings in the cabinet and push each end in until the grille locks into place. (See Fig. 17.)

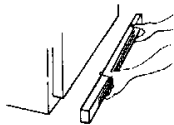

Fig. 17

Defrost Pan

Defrost water drains into a shallow pan located underneath the cabinet. This water evaporates over time. During periods of high humidity, water could remain in the pan.

Condenser Coil (WARNING - Edge's of the coil are sharp.)

The No Clean™ Commercial - Duty condenser of your refrigerator has been designed to operate efficiently without regular cleaning in normal home usage surroundings. (See Fig. 18.) Some operating environments may be particularly dusty or greasy. In these situations, the condenser can be periodically cleaned to insure maximum efficiency. In these circumstances, UNPLUG the refrigerator and move it away from the wall. Remove the machine compartment cover. Vacuum the condenser coil and surrounding area. Replace the machine compartment cover. Plug in the refrigerator after cleaning. To assist you in cleaning the condenser coil, you may obtain a condenser cleaning brush (part # 20001017) from your local Dealer.

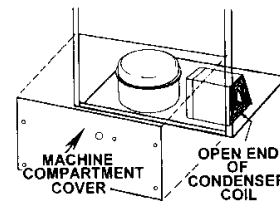

Fig. 18

Going On Vacation

If you will be gone for a month or less, leave the control knob at its usual setting.

During longer absences:

- Remove all food.
- Disconnect from electrical outlet.
- Clean the refrigerator thoroughly.
- Leave doors open to prevent odor formation.
- If the unit is equipped with an automatic ice maker, turn off the water supply to the unit.